

| ITEM NO. | DESCRIPTION | QTY. |
|----------|---|------|
| 1 | M32 Split gland, PC, IP67, EN 62444 class A, White, -20oC / +80oC | 1 |
| 2 | M32 Split Nut, PC, White, -40°C / +100°C | 1 |

Item Numbers 1 & 2 will be supplied to T3430, T3431, T3432, T3433 & T3434 as standard, please see the table below to find the insert that matches our part reference number

| ITEM NO. | DESCRIPTION | QTY. | ATL PART REF |
|----------|---|------|--------------|
| 3 | 5.5 - 8.0 M32 insert, TPE-V, -40oC / +135oC | 1 | T3435 |
| | 9.0 - 13.0 M32 insert, TPE-V, -40oC / +135oC | 1 | T3436 |
| | 11.5 - 15.5 M32 insert, TPE-V, -40oC / +135oC | 1 | T3437 |
| | 14.0 - 18.0 M32 insert, TPE-V, -40oC / +135oC | 1 | T3438 |
| | 17.0 - 20.5 M32 insert, TPE-V, -40oC / +135oC | 1 | T3439 |
| | 20.5 - 25.0 M32 insert, TPE-V, -40oC / +135oC | 1 | T3440 |
| | 24.0 - 26.5 M32 insert, TPE-V, -40oC / +135oC | 1 | T3441 |

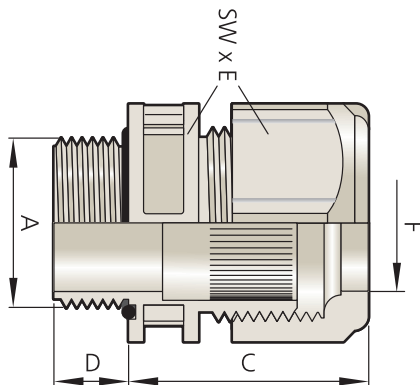

| M25 Split Gland Dimensions | |
|----------------------------|---------|
| Connection Thread (A) | M32x1,5 |
| D (mm) | 14.0 |
| F (mm) | 26.9 |
| Mounting Height C (mm) | 39.6 |
| Spanner Width (SWx E) | 46x51,3 |

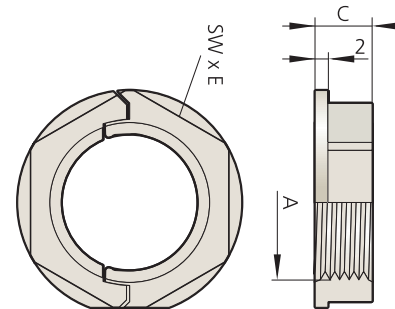

| M25 Split Nut Dimensions | |
|--------------------------|---------|
| Connection Thread (A) | M32x1,5 |
| Mounting Height (C) (mm) | 4.5 |
| Spanner Width (SWx E) | 36x39.5 |

PROPRIETARY AND CONFIDENTIAL
 THE INFORMATION CONTAINED IN THIS DRAWING IS THE SOLE PROPERTY OF ATL TRANSFORMERS LTD. ANY REPRODUCTION IN PART OR AS A WHOLE WITHOUT THE WRITTEN PERMISSION OF ATL TRANSFORMERS LTD IS PROHIBITED.

| | | | |
|-------|-------------|---|----------|
| | | ATL TRANSFORMERS LTD | |
| | | MIDDLETON, MANCHESTER M24 2HD TEL: 0161 653 0902 | |
| 1 | FINAL | C.J.W. | 07/10/19 |
| 0 | DRAFT | E.F. | 11/07/19 |
| ISSUE | DESCRIPTION | DRAWN | DATE |

UNLESS OTHERWISE SPECIFIED:
 DIMENSIONS ARE IN MM
 TOLERANCES:
 FRACTIONAL ± 0.1mm
 ANGULAR: MACH ± 0 BEND ± 0
 TWO PLACE DECIMAL ± 0
 THREE PLACE DECIMAL ± 0

Weight

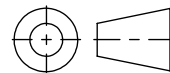

THIRD ANGLE PROJECTION

| | NAME | DATE |
|-----------|--------|----------|
| DRAWN | E.F. | 11/07/19 |
| CHECKED | C.W. | 11/07/19 |
| ENG APPR. | N.D.H. | 11/07/19 |
| MFG APPR. | | |
| Q.A. | | |
| Material | | |
| Finish | | |

| | | |
|---------------------------------|--------------|--------------|
| TITLE: | | |
| M32 Cable Gland Assembly | | |
| SIZE | Drawing. NO. | Issue |
| A | D1756 | 1 |
| SCALE: 1:2 | | SHEET 1 OF 1 |